

**ELEVATION VIEW**

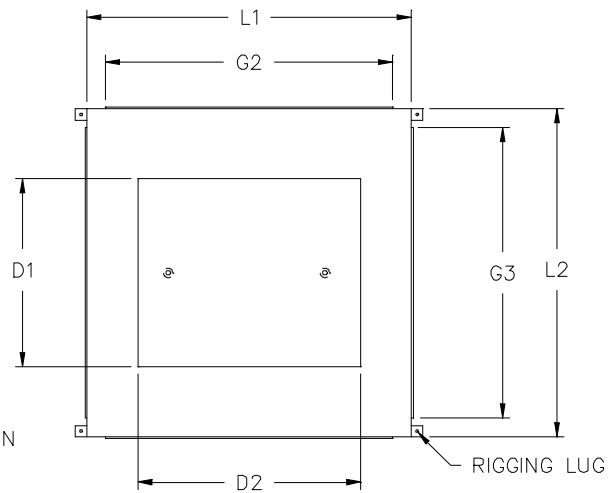

**PLAN VIEW**

**Specifications:**

The diffusers are constructed from 304 stainless steel and are double wall construction. The diffusers are insulated with a minimum of 1” of polystyrene insulation. The diffuser is sealed water tight for complete cleaning. The diffuser is complete with four, 4-way adjustable anodized aluminum grills. Stainless steel grills, volume dampers and heated bottoms are available.

Supply Air Diffusers										
Model	CFM	Dimensions (in)								Weight
		H	L1	L2	D1	D2	G1	G2	G3	
SA-03	2,500	16	24	24	12	12	10	14	14	100 #
SA-04	4,000	22	24	24	14	14	16	14	14	115 #
SA-05	5,000	22	30	30	18	18	16	20	20	120 #
SA-08	8,000	30	30	30	20	20	24	20	20	135 #
SA-10	10,000	30	40	40	24	24	24	30	30	155 #
SA-12	12,000	30	40	40	26	26	24	30	30	175 #
SA-15	15,000	36	40	40	30	30	30	30	30	220 #
SA-20	20,000	40	40	40	32	32	34	30	30	245 #
SA-25	25,000	40	52	52	40	40	34	42	42	310 #
SA-28	28,000	48	52	52	42	42	42	42	42	420 #
SA-35	36,000	36	52	108	56	40	30	42	98	500 #
SA-42	44,000	40	52	108	72	40	34	42	98	640 #
SA-50	50,000	54	52	108	84	40	48	42	98	960 #
SA-60	60,000	54	52	108	96	40	48	42	98	960 #
SA-70	70,000	68	52	122	114	40	62	42	112	1210 #
SA-80	80,000	68	52	122	120	40	62	42	112	1210 #